

16 Bit Micro Experimenter Assembly and Check out Instructions

The kit you purchased that includes PCB, schematic, complete parts list and these assembly instructions. A top picture of the complete assembly is shown.

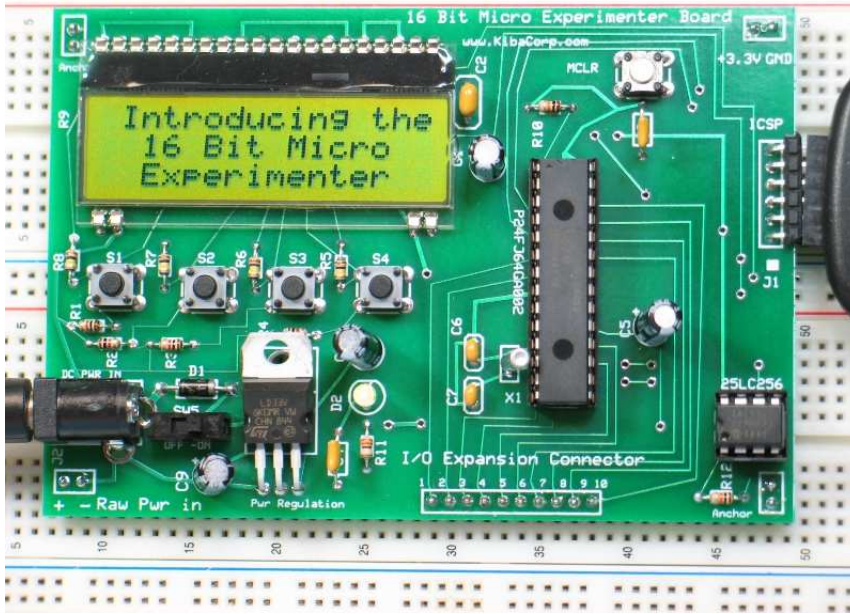

Figure 1 Top view

In addition, a picture is provided of both the top and bottom assembly together. This picture highlights the placements of the .100 headers which are mounted on the bottom of the PCB.



Figure 2 Top and Bottom Views

Assembly is straight forward. You will need a soldering iron, solder, and cutters. All parts are identified in the parts lists and their placement is identified on the board silkscreen per part number (i.e. C1, R10).

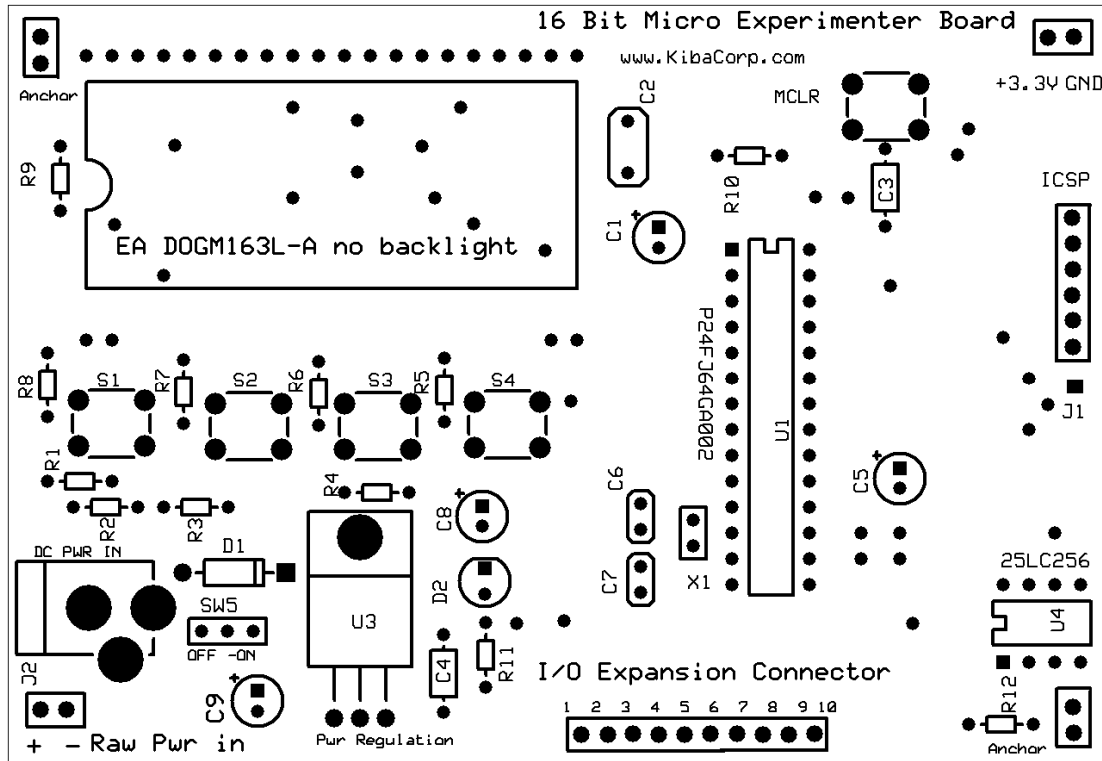

Figure 3 Board Silkscreen

Identify first the part itself from the parts lists and then, using silkscreen figure 3, where the part is located on the PCB by looking at the silkscreen labeling on the board, it will use a similar designator as the part number identified.

PARTS LIST

#	Designator	Description
1	J1	6 pin .100 header right angle
2	J2	Spark Fun DC power connector a 2.1mm center contact used for a wall transformer
3	J3	2 pin .100 header 10 pin
4	misc connector	dual pin .100 header qty 4 (2 anchor, 1 raw power, 1 +3.3V and GND out)
5	X1	Clock Crystal CY32.76
6	M1	DIP SOCKET 28-Pin 0.3" wide
7	M2	DIP socket 8 pin
8	D1	IN4001 Diode
9	D2	GREEN LED water clear Diode
10	S1	pushbutton
11	S2	pushbutton
12	S3	pushbutton
13	S4	pushbutton
14	S5	pushbutton

15	SW5	Slide Switch
16	C1	polarized cap marked 2.2uF
17	C2	cap .22uf marked 224
18	C3	.1uF marked 104
19	C4	.1uF marked 104
20	C5	polarized cap marked 10uF
21	C9	polarized cap marked 10uF
22	C6	33pF marked 330
23	C7	33pF marked 330
24	C8	polarized cap marked 100uF
25	R1	1K Brown-Black-red striped
26	R2	1K Brown-Black-red striped
27	R3	1K Brown-Black-red striped
28	R4	1K Brown-Black-red striped
29	R5	100K Brown-Black-yellow striped
30	R6	100K Brown-Black-yellow striped
31	R7	100K Brown-Black-yellow striped
32	R8	100K Brown-Black-yellow striped
33	R9	not required
34	R10	10K Brown-Black-orange striped
35	R11	330 Orange-orange-brown striped
36	R12	10K Brown-Black-orange striped
37	U1	Microchip Microprocessor PIC24FJ64GA002 28 pin DIP
38	U2	LCD Display EA DOGM163L-A
39	U3	+ 3.3V Regulator 3 lead T0-220 package
40	U4	Microchip EEPROM 25LC256P 8 pin DIP
41	board	PCB Board

You will need a soldering iron, solder, dykes (cutters), and needle nose pliers for assembly. In general you insert the part into the designated location from the top (exception is the .100 headers), then turn the board over (without have the part slip out or move away from the board) and then solder in place at the appropriate PCB silkscreen position. Clip the unnecessary lead length.

Recommended assembly procedure

1. The .100 headers **are installed from the bottom of the board.** This install is needed for both mechanical and electrical insertion of the Experimenter 16 into a solderless breadboard.
 - a. Install item #3 J3 into the bottom of the Experimenter where the I/O connector is located. Use whatever means at hand to insure all pins are flush to the PCB and are straight. Solder from top of PCB
 - b. Install item #4 misc connectors (4 dual pin items) in various locations on the PCB board from the bottom. Again insure all pins are flush to the PCB and are straight. Solder from top of PCB

- i. Anchor top left hand corner
 - ii. Anchor bottom right hand corner
 - iii. RAW PWR bottom left hand corner
 - iv. +3.3V and GND top right hand corner
2. Install item #1 J1 into ICSP pin array on to top of PCB. Solder from bottom, make sure pin array is flush with top surface of PCB.
3. Install item #6 28 pin socket M1 for PIC24J64GA002 processor U1 on to top of PCB, Align notch in socket with notch on breadboard. Make sure socket is flush with top and breadboard. Solder from bottom.
4. Install item # 7 8 pin socket M2 for 25LC256 EEPROM on to U4 top of PCB, Align notch in socket with notch on breadboard. Make sure socket is flush with top and breadboard. Solder from bottom.
5. Install polarized capacitors on to board from top. Align polarity of part in occurrence with silkscreen (note the – label on part it opposite the + label on silkscreen). Solder from bottom. Remove excess leads on bottom of board with dykes.
 - a. Item # 16 C1 polarized cap 2.2uf
 - b. Item #20 C5 polarized cap 10uF
 - c. Item #21 C9 polarized cap 10uF
 - d. Item #24 C8 polarized cap 100uF
6. Install item # 2 J2 DC barrel connector onto top of PCB at J2. Solder from bottom.
7. Install item #14 SW5 Slide switch into PCB at SW5. Solder from bottom
8. Install item # 8, diode D1, and item #9, diode D2 an LED, onto top of PCB. D2 the LED its cathode is the shorter lead of the leads. Make sure the part orientation for cathode aligns with the cathode designation on the PCB. Solder from bottom. Remove excess leads on bottom of board with dykes.
9. Install item #39 U3 onto top of PCB. Solder on bottom of PCB. I bent mine to keep it out of the way, but please ensure its collector (the metal tab) does not touch the board (see pictures). Remove excess leads with dykes.
10. Install item # 35 R11 and item # 19 C4 onto PCB from top. Solder from bottom and remove excess leads with dykes. You have now completed the Power regulator section of the module. If you have a Voltmeter you can check that +3.3 volts is being produced on the board. First apply power either through a positive center DC wall transformer or directly through the + and _ RAW power inputs. Use anywhere from +5VDC to +9VDC as input. Use voltmeter to check power at the +3.3V and GND pins in the upper left hand corner of the PCB. Be sure to switch SW5 power switch to ON position.
11. Install pushbutton onto board. They should only fit in one orientation. Insert onto top of PCB and solder on the bottom of PCB.
 - a. Item # 10 S1
 - b. Item # 11 S2
 - c. Item # 12 S3
 - d. Item # 13 S4
 - e. Item # 14 S5 MCLR

12. Install resistors to top of PCB board. Solder from bottom. Remove excess leads on bottom of board using dykes. Note R9 is left empty and is not used.
 - a. Item #25 R1 1K Brown-Black-red striped
 - b. Item #26 R2 1K Brown-Black-red striped
 - c. Item #27 R3 1K Brown-Black-red striped
 - d. Item #28 R4 1K Brown-Black-red striped
 - e. Item #29 R5 100K Brown-Black-yellow striped
 - f. Item #30 R6 100K Brown-Black-yellow striped
 - g. Item #31 R7 100K Brown-Black-yellow striped
 - h. Item #32 R8 100K Brown-Black-yellow striped
 - i. Item #34 R10 10K Brown-Black-orange striped
 - j. Item# 36 R12 10K Brown-Black-orange striped
13. Install remaining capacitors to top of PCB board. Solder from bottom. Remove excess leads on bottom of board using dykes.
 - a. Item #17 C2 cap .22uf marked 224
 - b. Item #18 C3 .1uF marked 104
 - c. Item #22 C6 33pF marked 330
 - d. Item #23 C7 33pF marked 330
14. Install item #5 Clock Crystal CY32.76 onto top of PCB at location marked X1. . Solder from bottom. Remove excess leads on bottom of board using dykes.
15. Finally install item #38 LCD Display on to top of PCB board at U2 designation. It only fits on the PCB in one orientation. You may have to move pins around slightly to align with holes. Place unit nearly flush with PCB or as close as possible without damaging the glass unit. Solder from bottom. Remove excess leads on bottom of board using dykes. Once installed remove thin protective film that is pasted on top of the display glass. Careful not to damage or scratch the glass.
16. Insert into sockets already installed on PCB the following ICs. For these IC parts U1, U4 match the notch orientation of the chip package with notch orientation indicated on the socket and PCB at these designated location. Insure that the parts are completely inserted into their respective sockets.
 - a. Item #37 U1 Microchip Microprocessor PIC24FJ64GA002 28 pin DIP
 - b. Item #40 U4 Microchip EEPROM 25LC256P 8 pin DIP

Power-up and testing the Experimenter

Once assembly is completed we need to apply a +6VDC to +9VDC source.

Apply power through wall transformer or through RAW + and -. Turn on the power switch. Since the kit comes with a pre-programmed PIC24FJ64GA002 you should see the flash screen demo come up immediately. Once satisfied with flash screen operation try the demos. Buy a large solderless breadboard (3260 contacts), plug in the Experimenter and add hardware as needed for Thermometer and RGB light demos. Details on demos and tools for the 16 Bit experimenter can be accessed on the KibaCorp Web Site www.KibaCorp.com

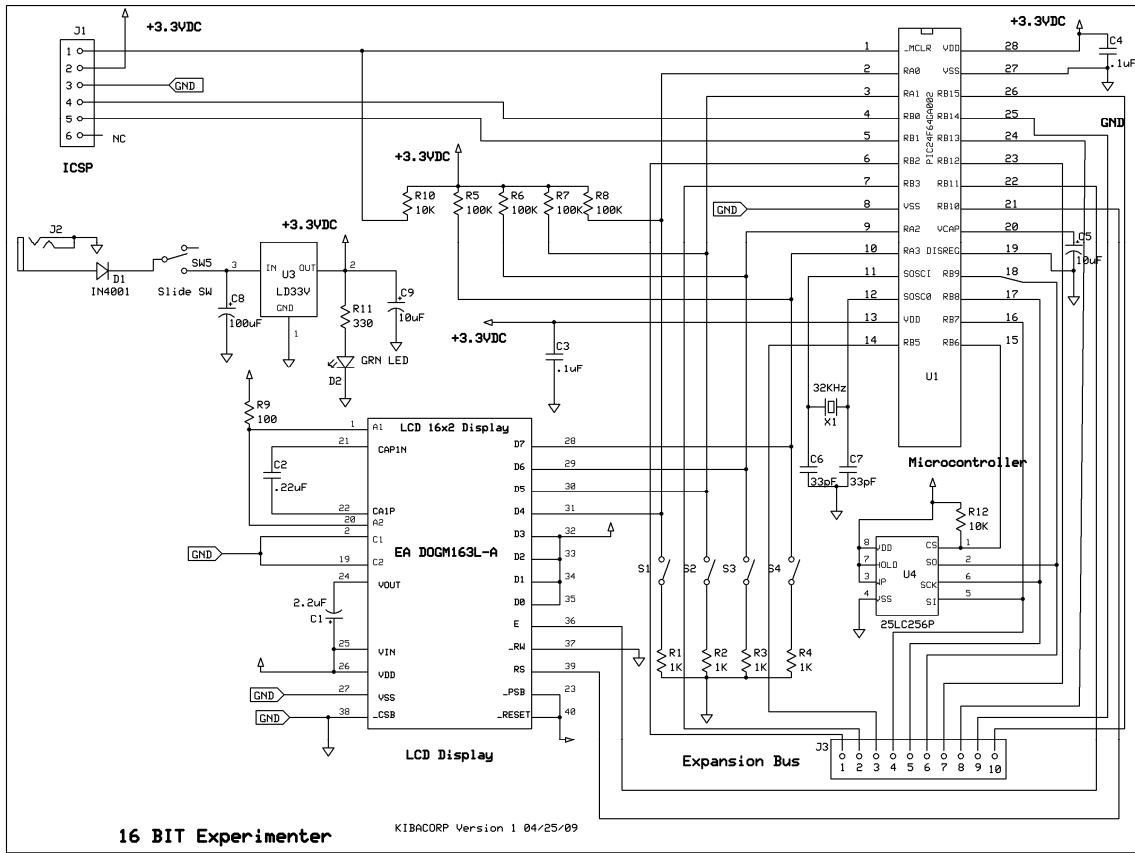

Figure 4 Schematic